

# Comparison lamps automation

---

**CTIO 60 inches Echelle**

**ECH60S-5.1**



**La Serena, December 09, 2009**

# Contents

Introduction.....	3
1.- Module.....	4
2.- External wiring.....	5
3.- Internal logic.....	7
4.- Conclusion / General notes.....	9
Acknowledgments.....	10
References.....	11
Appendix A: final schematic (C1 rev B).....	12

## Introduction

The present document is just a brief summary of the work done automating the 60 inches echelle comparison lamps. This report does not pretend to be a comprehensive study of the electronics/lamps mechanism, and it is not intended to replace the appropriate schematic documentation; it just provided in order to supply a reference for future usage. This document does not describe the upper level software (host) that handles the lamps, but just the hardware and firmware involved.

The echelle has currently two comparison lamps. This lamps were originally (before this upgrade) manipulated by a manual three positions switch (right, off, left) that the operator/observer would manipulate manually when required.

The automation process was done simply by adding a digital I/O module that can receive requests through the network, allowing in this way a software-operated mechanism. After the upgrade both the manual and the remote operations are possible.

## **1.- Module**

The digital I/O module selected was the ADAM-6050, because it provides a simple interface (ASCII commands) and also provides some very nice firmware logic programming (the so-called GCL registers). It is also very easy to program, and the outputs are open collector, which are the perfect fit for the electronic control. This module uses Modbus or UDP protocols for the remote (Ethernet) interface.

## 2.- External wiring

**Figure 1** shows the external wiring diagram. The manual switch was used as digital inputs (**Di0** and **Di2**), which allowed to keep the manual switch functionality untouched. The Digital Output 1 and 3 (**Do1** and **Do3**) were used to produce the actual control signals. Digital outputs 1 and 2 (**Do1** and **Do2**) appear unused in the diagram, but they are actually being used as the software-commanded outputs, which are combined internally with the digital inputs from the switches to produce the actual output signals (see point 3.0 below). The actual control signals are being connected into digital inputs (**Do1 -> Di1**, and **Do3->Di3**) to have a reading of the actual output, producing a basic feedback on the control signals.

Digital output 5 (**Do5**) was used to produce the motor control. This signal is produced internally in the ADAM module (see point 3 below). The motor control is also connected to a digital input (**Do5 -> Di5**) to have feedback on the actual output.

The ADAM module is connected to the network to be commanded remotely. All the output signals are open collector, and all the signals are considered to be “**active low**” (a logic **0** means **5 Volts** –open-, and a logic **1** means **0 Volts** –grounded-).

The power for the ADAM module was taken from the existing 12 Volts control box supply. The ground of the ADAM module was connected to the 12 volts ground supply. The input/output ground reference was also connected to the same ground (not shown in the diagram)

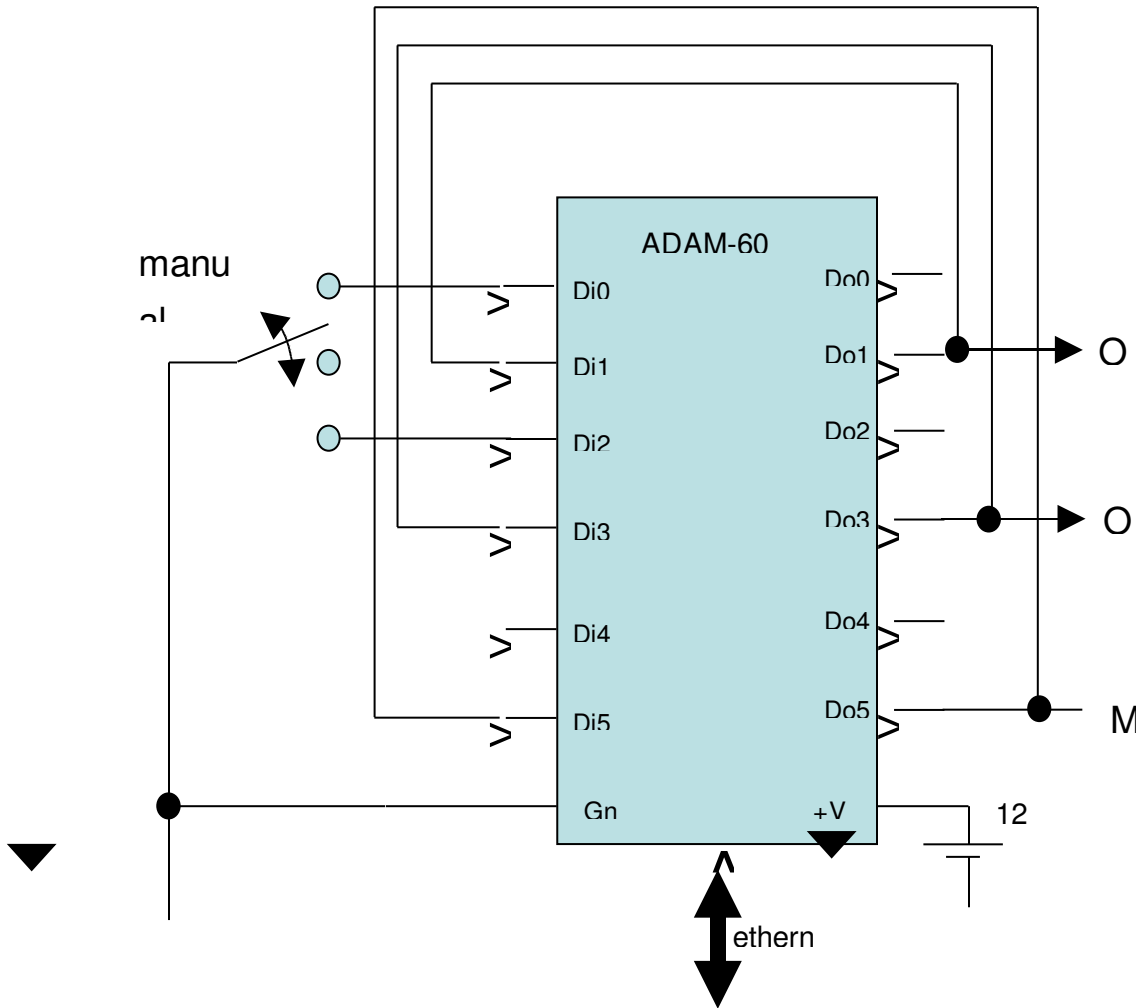

Figure 1: External wiring of the ADAM module

### 3.- Internal logic

The module was programmed internally so it will produce the actual control outputs for the lamps combining the digital inputs (**switches**) and the commanded outputs (**software command through the network**). **Figure 2** shows the diagram of the internal programmed logic.

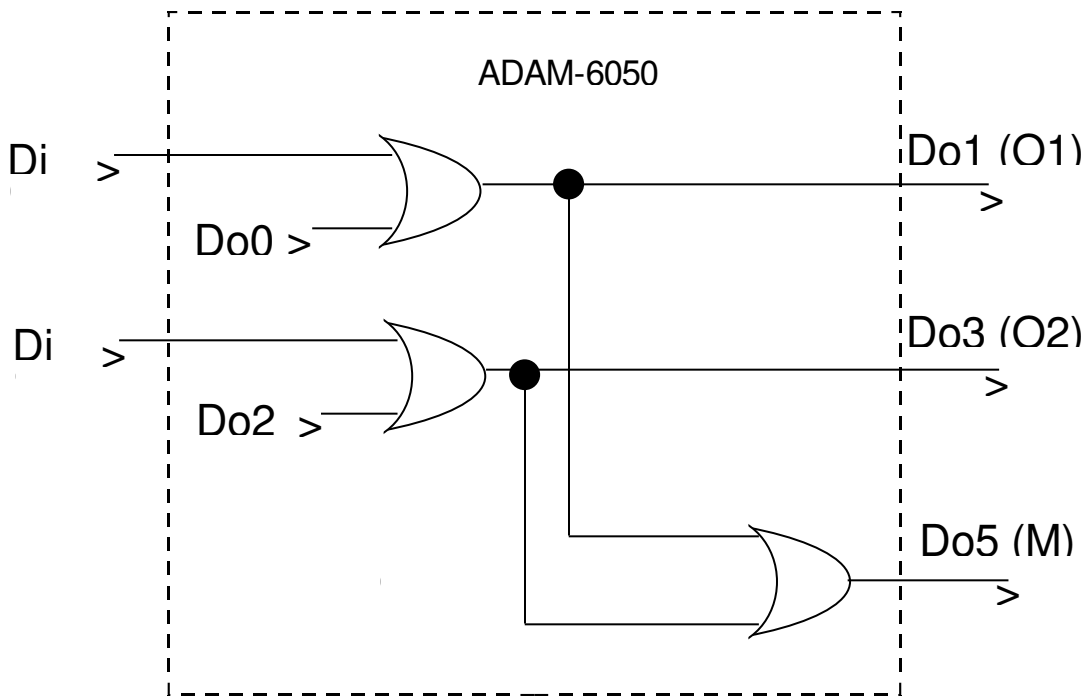

Figure 2: Internal ADAM logic

The module provides an **OR** between the digital input 0 (switch position 1) and the digital output 0. The digital output 0 is the one that the high level software needs to set when sending a remote command. The result of the **OR** gets routed into digital output 1, that becomes the actual externally wired control **O1**. Remember that a logic1 really means 0 volts (active low)

A totally symmetrical logic applies for switch digital input 2 (switch position 2) and digital output 2, producing the control output **O2**

The motor output (**M**) gets generated as an **OR** between both actual control lamp outputs, **Do1** (wired **O1**) and **Do3** (wired **O2**), which means that anytime a control signal is present (either **O1** or **O2**) the motor output **M** will become “active”. Traduced into lamp signals, every time a lamp is “on” the motor will be active.

The internal logic (GCL) was programmed using the ADAM .Net Utility for series 5000-6000, provided by Advantech



## 4.- Conclusion / General notes

- After the upgrade, the old manual mechanism is still the same –the operator can manipulate the switches manually, as always
- Besides the manual control, now it is possible to turn on/off the lamps automatically through a network command.
- The **ADAM module**, after programmed as shown above, becomes **totally stand-alone**, meaning that it does not require a host or an Ethernet connection to work. As soon as the unit is powered the internal logic becomes active. The Ethernet connection is necessary only for the software (automatic) commands.
- The ADAM Ethernet protocol provides two interfaces: plain ASCII commands using UDP protocol on ports 1024 and 1025, and ModBus protocol. See the ADAM 6000 user manual for details.

## **Acknowledgments**

Thanks to Javier Rojas for installing and wiring the ADAM module in the control box, for checking the logic and testing the final product.

Thanks to Enrique Schmidt and Humberto Orrego for providing feedback on the manual switches operation.

## References

- *ADAM 6000 series User Manual*  
*Advantech Co. Ltd, 3th edition, January 2008*
- *ADAM .Net utility, series 4000/5000/6000, version 2.00.06*  
-
- *Electronics of the 1.5 meters fiber echelle front end module*  
*A.Tokovinin, April 23, 2008*
- *CI rev A schematic*  
*R.Leiva, April 2009*

# Appendix A: final schematic (C1 rev B)

