

Design of the CHIRON high-resolution spectrometer at CTIO

Christian Schwab^{*a}, Julien F. P. Spronck^b, Andrei Tokovinin^c, and Debra A. Fischer^b
^aLandessternwarte, University of Heidelberg, Königstuhl 12, 69117 Heidelberg, Germany
^bYale University, 260 Whitney Avenue, New Haven, CT, USA
^cCTIO, Casilla 603, La Serena, Chile

ABSTRACT

Small telescopes coupled to high resolution spectrometers are powerful tools for Doppler planet searches. They allow for high cadence observations and flexible scheduling; yet there are few such facilities. We present an innovative and inexpensive design for CHIRON, a high resolution ($R \sim 80,000$) Echelle spectrometer for the 1.5m telescope at CTIO. Performance and throughput are very good, over the whole spectral range from 410 to 870nm, with a peak efficiency of 15% in the iodine absorption region. The spectrograph will be fibre-fed, and use an iodine cell for wavelength calibration. An image slicer permits a moderate beam size. We use commercially available, high performance optical components, which is key for quick and efficient implementation. We discuss the optical design, opto-mechanical tolerances and resulting image quality.

Keywords: Spectrometer design, high resolution spectrograph, Iodine cell technique, Echelle

1. INTRODUCTION

We describe here the design of a new precision radial-velocity (RV) spectrometer, CHIRON¹. It is now under construction, to be installed soon at the CTIO 1.5-m telescope. Reaching state-of-the art precision in radial velocities places challenging requirements on the spectrographs: sufficient spectral resolution, high throughput, and, most importantly, stability of the point spread function (PSF). Although iodine lines imprinted in the stellar spectrum provide first-order correction for many instrumental effects^{2,3}, the ultimate limit on RV precision depends on the instrument stability. Our goal is to detect rocky planets of terrestrial masses around bright nearby stars. A long-term RV precision of 10 cm/s is needed.

After investigating the common optical design for high resolution spectrographs, namely Littrow⁴, pseudo-Littrow⁵ and white pupil designs⁶, and comparing their respective merits and drawbacks for our project, we decided on a pseudo-Littrow configuration. This allows us to use inexpensive, commercial optics, while retaining excellent optical quality and the desired specifications for resolution and throughput. The spectrograph is located in the coude room below the observing floor, and coupled to the telescope by means of an optical fibre with 100 micrometer diameter, operated at $f/5$.

2. FIBRE FEED

The fibre feed is permanently installed at the Guiding and Acquisition Module (GAM) of the 1.5m telescope. Stellar light is deflected to the fibre feed by an elliptical mirror placed on top of the guider arm, when the arm is positioned at the center of the field. Otherwise, the GAM works as usual.

Figure 1 gives a general view of the fibre feed. A slightly concave metallic mirror is placed in the focal plane. The image is focused on a hole of 150 μm diameter (2.7" on the sky), then reformed on the fibre entrance with a de-magnification of 3:2 by a pair of small achromatic lenses. The light which is not passed by the hole is reflected towards the guiding camera – a GC650 CCD from Prosilica with Ethernet interface. The light of comparison lamps is brought through a 0.4 mm fibre from a separate box. A 2 mm prism actuated by a cam slides behind the aperture mirror for calibration exposures. The fibre feed is in use since 2008, in combination with the old Blanco echelle spectrometer.

* cschwab@lsw.uni-heidelberg.de

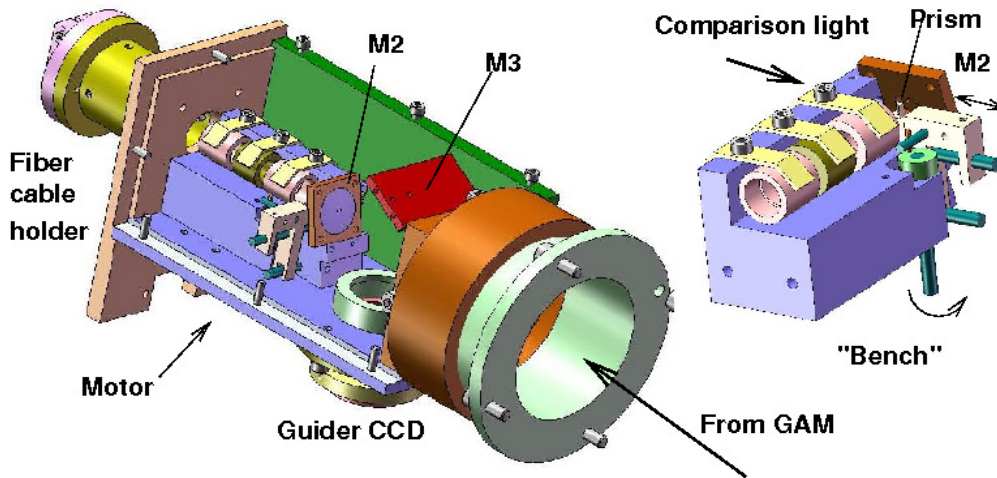

Figure 1. CAD images of the fibre feed front module.

3. LAYOUT

The layout of the optics is shown in Figure 2. The output of the fibre is imaged onto an image slicer, which in turn is reimaged into the focus of a parabolic mirror serving as collimator. The relay system around the slicer also provides a collimated space where we can insert the iodine gas cell. We re-use an existing R2 grating with 31.6 lines per mm as the main dispersive element. Cross-dispersion is provided by a prism that follows the grating. A refractive camera images the spectrum onto a 4 x 4k back-illuminated CCD detector with a format of 60 x 60 mm. A folding flat between the camera's front lens group and the CCD allows for a compact arrangement on a standard optical table. The spectral format on the detector spans from 410 to 880 nm in 73 orders.

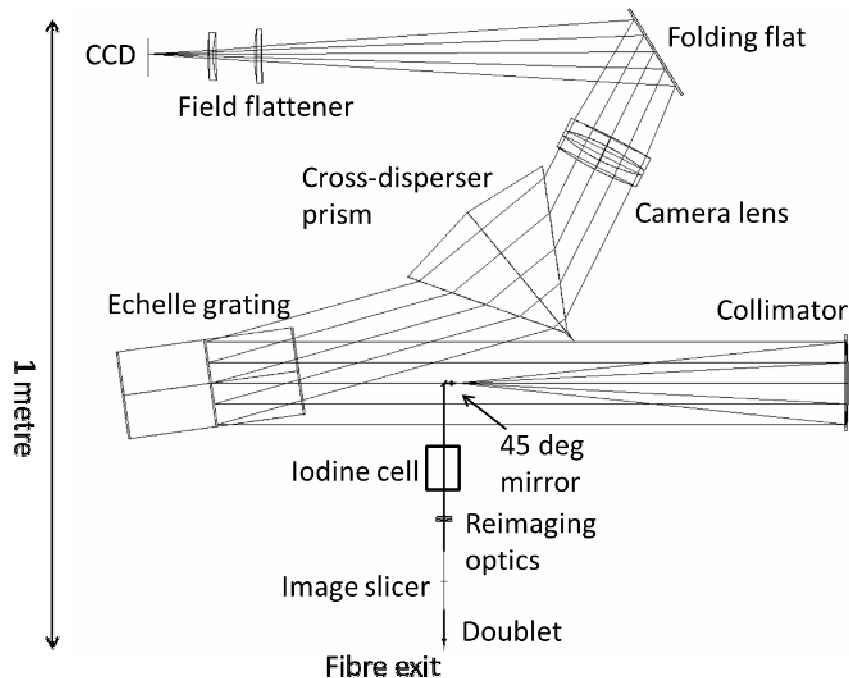

Figure 2. Optical layout of the spectrograph. The components are oriented in a plane. A folding flat within the camera permits a compact footprint.

4. OPTICAL COMPONENTS

4.1 Fibre and image slicer

The beam emerges from the fibre with 100 μm core at $f/5$. Slicing the fibre image three times gives a projected “slit” of 50 x 450 μm considering the camera’s focal ratio of 7.1, well matched to the CCD pixel size and our envisaged resolution. The resulting resolution is 83.000, slightly oversampled with 3 pixels per slit width. We adopt the Bowen-Walraven design for the slicer. Two mirrors with high reflectivity coatings are used, rather than the total internal reflection in prisms commonly used in other slicers. It is straight forward to achieve the crucial sharp edge of the substrate. Due to the high reflectivity of modern coatings, the efficiency of such a slicer is very good. It is very flexible as the gap can be adjusted. A prototype showed excellent results (Figure 3).

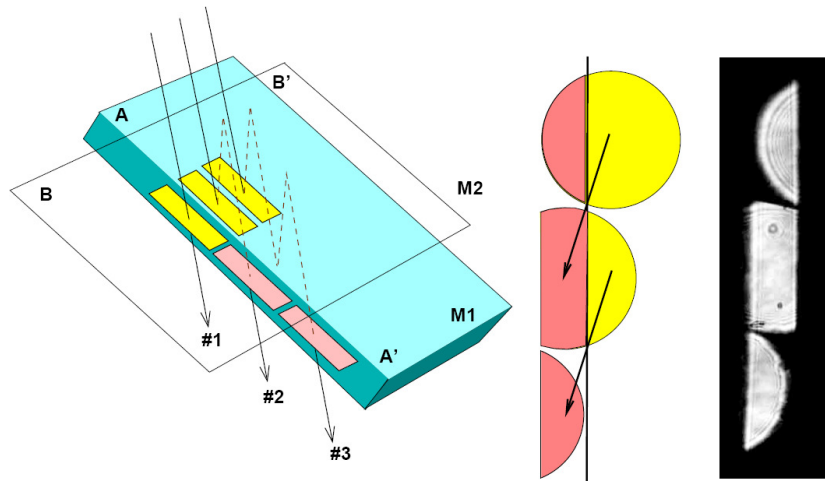

Figure 3. The Bowen-Walraven type image slicer. A beam with low F-ratio is sliced by the sharp edge of the mirror M1. The first slice #1 goes past the edge. The remaining light bounces between mirrors M1 and M2 and goes past the edge with some lateral shift, forming the slice #2. The third slice is produced after 4 reflections. The resulting slices from a prototype are shown on the right.

4.2 Collimator

We use an on-axis parabolic mirror as a collimator, facilitating ease of alignment, and ensuring high optical quality. The necessary central obstruction is minimal, of 15-mm diameter. The mirror is in hand and has an aperture of 150 mm and a focal length of 600 mm. The mirror was manufactured by Orion Optics, UK, and selected for wavefront accuracy. The measured surface error of a 140 mm aperture is better than $\lambda/20$.

4.3 Cross disperser prism

We opted for a single prism as cross-disperser to guarantee the highest possible throughput. We were able to obtain a single block of Schott LF7 big enough to manufacture a monolithic prism with clear surfaces of 260 by 160 mm. With this glass, the inter-order separation varies by a factor of 1.9. The block came with no enhanced homogeneity specification. After cutting the prism and a first polishing of the sides, interferometric measurements showed a wavefront error of approximately 600 nm peak to valley (PV). This is partly due to deviations of the polished surfaces and inhomogeneities in the glass. The prism is currently being retouched by TORC in Tucson, AZ, to achieve a wavefront error of less than 150 nm PV.

4.4 Camera optics

For the camera we use a high-end amateur telescope / astrograph from Telescope Engineering Company (TEC). The system comprises a 140 mm oil-spaced triplet lens plus a two-element field flattener with a focal length of 1000 mm.

Theoretical image quality over the whole illuminated circle of 85 mm diameter is very good. We were able to confirm this on the actual lens we will use. Figure 4 shows the PSF of the camera optics in double pass; the box size is 70 μm . The prevalent aberration is chromatic defocus, which we can correct by tilting the CCD slightly. State-of-the-art anti-reflection coatings come as a standard feature.

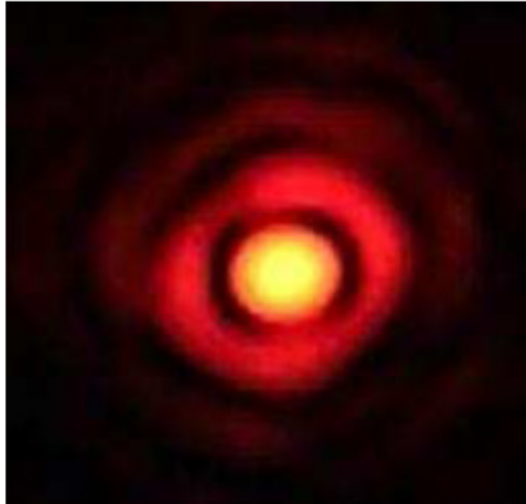

Figure 4. Image of the PSF produced by camera on the axis, in double pass. The box size is 70 μm .

4.5 Detector

The detector to be used with CHIRON is a back-illuminated CCD from E2V with 4k by 4k 15 μm pixels. The dewar and electronics are manufactured in-house at CTIO. Quantum efficiency and noise characteristics of this device are excellent. The device is scheduled to be shipped in June 2010.

5. DESIGN PERFORMANCE

5.1 Image Quality

The resulting performance of the whole spectrograph design is very good across the full spectral range. The Echelle format on the detector is shown in Figure 5(a). Spot diagrams for the corners of the format as well as the centre are shown in Figure 5(b)-(f). The theoretical spots are well within one resolution element for all wavelength. The wavefront degradation by each of the optical elements is small. Ultimately, we believe image quality to be limited by the wavefront error introduced by the grating.

5.2 Throughput

We estimate the throughput of the system at the blaze peak, including the telescope, fibre, spectrometer and detector, to be 15% at 500 nm. We have measured the throughput of our optics and find that the primary and secondary telescope mirrors are 87% each, the fibre link - including the relay optics, image slicer and seeing effects - is conservatively assumed to have a transmission of 42%, the collimator has 96% reflectivity, the echelle has a throughput of 65%, the prism throughput is 95%, the throughput of the camera and the folding flat is 98% and 96%, respectively, and the QE of the e2v CCD is 88%.

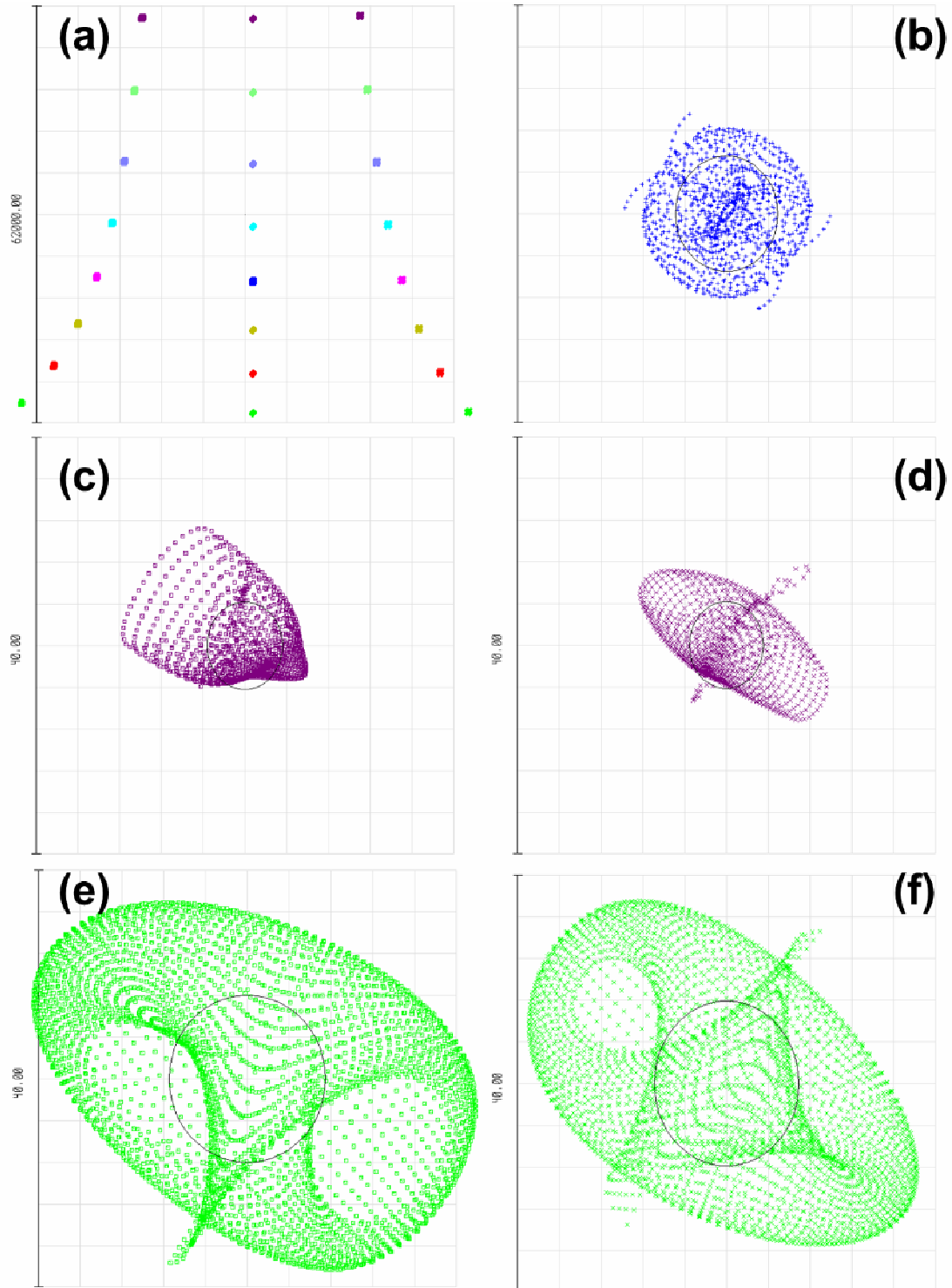

Figure 5. Plot of the echelle format as it appears on the CCD (a). Every 10th order is shown, with central wavelength and the end of the free spectral range (FSR). Spot diagrams for a wavelength in the centre of the CCD chip (b) and the corners. The ends of the FSR in the bluest order are shown in (c) and (d), for the reddest order in (e) and (f). The box size for the spot diagrams is 40 microns, about the size of one resolution element.

6. MECHANICAL DESIGN

The mechanical design of the instrument is based on two parts: an instrument support structure (ISS) and an optical table (see Figure 6). The ISS is constructed from U-shaped steel profiles, welded together to form two stiff frames connected by diagonal struts. The frames support the CCD dewar and an optical table, on which all components are mounted. The whole instrument will be enclosed and the interior temperature and pressure will be actively controlled. The field flattener serves as a sealing window toward the CCD. The fibre feed-through and the relay lenses are contained in a so-called foreoptics box (FOB). Focussing is achieved by moving the camera lens with a linear translation stage.

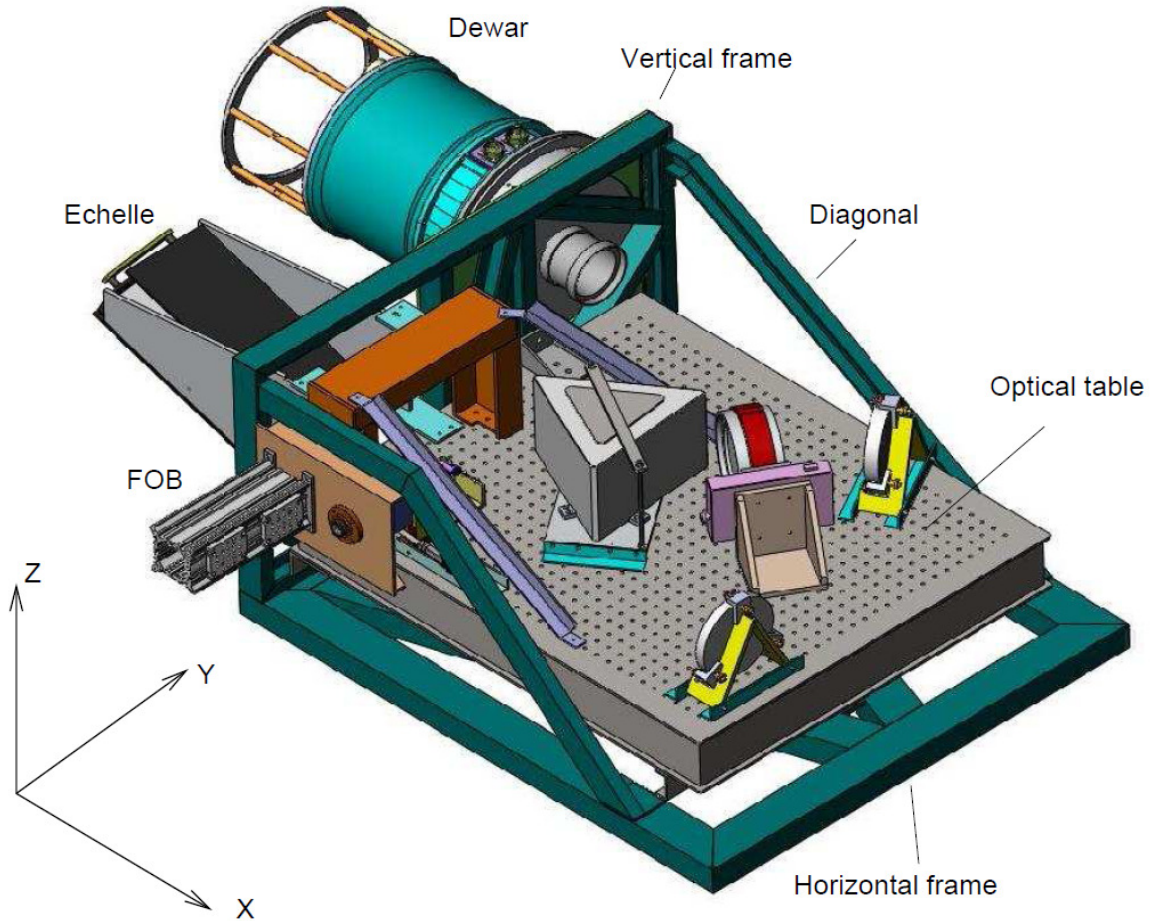

Figure 6. CAD drawing of the whole assembly. In the centre, the optical breadboard on which the components are mounted. The breadboard is attached at three points to the structure made from welded steel. The camera dewar also interfaces to this structure. The whole assembly will be boxed by insulating, airtight panels mounted to the steel frames.

7. CONCLUSIONS

We have presented the optical and mechanical design of the Chiron spectrograph for the 1.5 m telescope at CTIO. The design is simple, yet efficient, with very good image quality and throughput over the whole spectral range, from 410 to 870 nm. We have incorporated commercially available optics in the design to produce a high quality instrument with relatively low risk, on a manageable budget. We expect this spectrograph to be a valuable addition to the facilities at CTIO.

ACKNOWLEDGEMENTS

We would like to thank Andrew Rakich and Steve Schectman for helpful discussions, and our design reviewers Andrew Szentgyorgyi and John Hearnshaw for their constructive comments. Fischer acknowledges funding from the NSF MRI program AST-0923441. CS is a member of the International Max Planck Research School (IMPRS) in Heidelberg.

REFERENCES

- [1] Schwab, C., Spronck, J. F. P., Tokovinin, A., Fischer, D. A., Marcy, G.W., "CHIRON - a new high resolution spectrometer for CTIO", to appear in the proceedings of "New Technologies for Probing the Diversity of Brown Dwarfs and Exoplanets", Shanghai (2009).
- [2] Butler, R. P.; Marcy, G. W.; Williams, E.; McCarthy, C.; Dosanji, P.; Vogt, S. S., "Attaining Doppler Precision of 3 M s⁻¹.", *PASP*, v.108, p.500 (1996).
- [3] Valenti, J., Butler, R.P., and Marcy, G.W., "Determining Spectrometer Instrumental Profiles using FTS Reference Spectra", *PASP*, Volume 107, 966 (1995).
- [4] Crane, J. D., Shectman, S. A., Butler, R. P., "The Carnegie Planet Finder Spectrograph", *Proc. SPIE*, Volume 6269, pp. 626931 (2006).
- [5] Skuljan, Jovan; Hearnshaw, John B.; Cottrell, Peter L., "High-Precision Radial Velocity Measurements of Some Southern Stars", *PASP*, Volume 112, Issue 773, pp. 966-976 (2000).
- [6] Baranne, A.; Queloz, D.; Mayor, M.; Adrianzyk, G.; Knispel, G.; Kohler, D.; Lacroix, D.; Meunier, J.-P.; Rimbaud, G.; Vin, A. "ELODIE: A spectrograph for accurate radial velocity measurements.", *Astronomy and Astrophysics Supplement*, v.119, p.373-390 (1996).